

系列数控板料折弯机 CNC Sheet Metal Pressbrake

PBH PBA 大型折弯机 PBH PBA Heavy Duty Pressbrake

**Yawei 亚威**

股票代码 002559

Stock Code 002559

因为专注 所以专业

Dedication to Professionalism

产品目录 Product Catalogue

因为专注 所以专业 ————— 02
Dedication to Professionalism

PBH系列 ————— 04
PBH Series

PBA系列 ————— 06
PBA Series

技术参数 ————— 08
Technical Specification

通用部件 ————— 12
Options

装备精良 质量保证 ————— 16
Well-equipped Quality Assured

客户案例 ————— 18
Customer Installations

三十多年来，亚威一直致力于大型折弯机领域的创新研发与制造，已积累大量成功经验、涉足众多的行业、拥有广泛的高端客户。

PB系列大型折弯机是您量身定制的最佳解决方案，您可以自由选择折弯力、长度等参数，并可选择合适的功能部件是国内最大的、设备最先进的、工艺最有保障的大型折弯机研发和生产制造基地。

For over 30 years, Yawei has been dedicated to the R & D and manufacturing of heavy duty Pressbrake. Yawei has a large installed base in numerous industries with a wide range of customers.

PB series heavy duty pressbrake are the best solution, with a wide range of tonnages and lengths to choose from and many options to meet all your requirements.

Yawei has the largest R & D and manufacturing center in China, with the most advanced facilities and proven techniques.

PB系列大型折弯机 PB Series Heavy Duty Pressbrake

- 源于欧洲技术
- 单机最大折弯为50000KN
- 单机最大折弯长度18000mm
- 双机或多机联动
- European technology
- Single machines upto 50,000KN of Force
- Single machines upto 18,000mm in length
- Tandem of double or multi-machines



PBH 系列大型折弯机

PBH Series Heavy Duty Pressbrake

- 单机折弯力最高可达50000KN，能够对大型工件进行折弯
- 标准液压补偿工作台结构设计，操作简单，稳定可靠
- Single machine up to 50,000KN of force
- Standard 3 piece bed design with integrated hydraulic bed crowing, easy operation, stable and reliable



PBA 系列大型折弯机

PBA Series Heavy Duty Pressbrake

- 单机折弯力最高可达50000KN，能够对大型工件进行折弯
- 机械补偿工作台设计，精度调整方便，操作快捷
- Single machine up to 50,000KN of force
- Customized bed design with mechanical bed crowing, easy adjustment and operation



双机联动 系列大型折弯机

Tandem Series Heavy Duty Pressbrake

- 单机折弯力最高可达50000KN，能够对超长厚工件进行折弯
- 个性化参数设计，适合钢管灯杆、大型构件的折弯加工
- 可实现双机或三机联动
- Single machines up to 50,000KN
- Customized parameter design options used for processing lamp posts and large work pieces
- Tandem functions for use on 2 or 3 machines

PBH系列 大型折弯机

PBH Series Heavy Duty Pressbrake

- 先进设计，高速度、高精度、高刚性的数控板料折弯机
- 优质的钢板原材料，大型五面体加工中心，是亚威高品质的保证
- 电液伺服系统，全闭环控制滑块
- 滑块双导轨结构，自润滑导轨，确保滑块长久精确运行
- 工作台液压挠度补偿和喉口变形补偿机构，确保折弯精度
- 油缸球面浮动支撑结构，活塞杆特殊导向结构，抗偏载能力强
- 后挡料采用数字式交流伺服电机驱动，精密滚珠丝杆传动，直线导轨导向

- CNC Pressbrake featuring an advanced design with high speed, high accuracy and excellent rigidity
- Yawei machines are produced using high quality, world class steel plate and a large scale pentahedron machining center
- An Electro-hydraulic full loop servo system controlling the synchronization of the ram
- Dual gibbed ram structure with a self-lubrication system guarantees precise operation
- CNC Hydraulic crowning system with a 3 piece bed design and c-frame throat deformation compensation systems ensure precision bends
- Cylinders are attached to ram with spherical floating supports and the piston and rod is equipped with a unique guiding system to assist during unbalanced loading
- Backgauge components include: digital AC servo motors with precision ball screws and linear guide

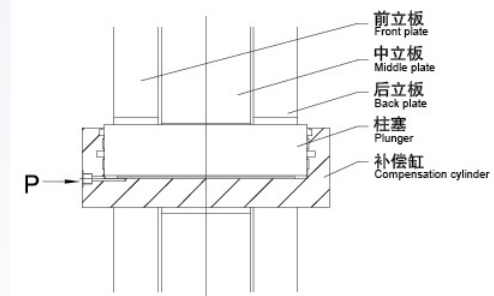

采用液压挠度补偿，可获得在工作台全长上精度均匀一致的工件。液压挠度补偿由一组在下工作台内的油缸组成，可使工作台相对移动，形成加凸的理想曲线，保证受力后与滑块的相对位置关系不变。补偿量由数控系统根据板厚、模具开口及材料特性自动计算确定。

The integrated CNC bed crowing system utilizes a 3 piece bed design with hydraulic cylinder mounted in the bed. The cylinders are used to counteract the bending force to keep the worktable and work piece flat during the bending process. This ensures a quality part. The crowing is controlled automatically by the CNC system according to the location and force required to form the part.

PBA系列 大型折弯机

PBA Series Heavy Duty Pressbrake

- 先进的设计，高速度、高精度、高刚性数控板料折弯机
- 优质的钢板原材料，大型五面体加工中心，是亚威高品质的保证
- 电液伺服系统，全闭环控制滑块同步
- 滑块双导轨结构，自润滑导轨，确保滑块长久精确运行
- 工作台机械挠度补偿和喉口变形补偿机构，确保折弯精度
- 油缸球面浮动支撑结构，活塞杆特殊导向结构，抗偏载能力强
- 后挡料采用数字式交流伺服电机驱动，精密滚珠丝杆传动，直线导轨导向
- CNC Pressbrake featuring an advanced design, with high speed, high accuracy and excellent rigidity
- Yawei machines are produced using high quality, world class steel plate and a large scale pentahedron machine center
- An Electro-hydraulic full loop servo system controlling the synchronization of the ram
- Dual gibbed ram structure with a self-lubrication system guarantees precise operation
- Mechanical bed crowning with C-frame deformation compensation system ensures precise bends
- Cylinders are attached to the ram spherical floating support and the piston rod is equipped with a unique guiding system to assist during unbalanced loading
- Backgauge components include: digital AC servo motors with precision ball screws and linear guides

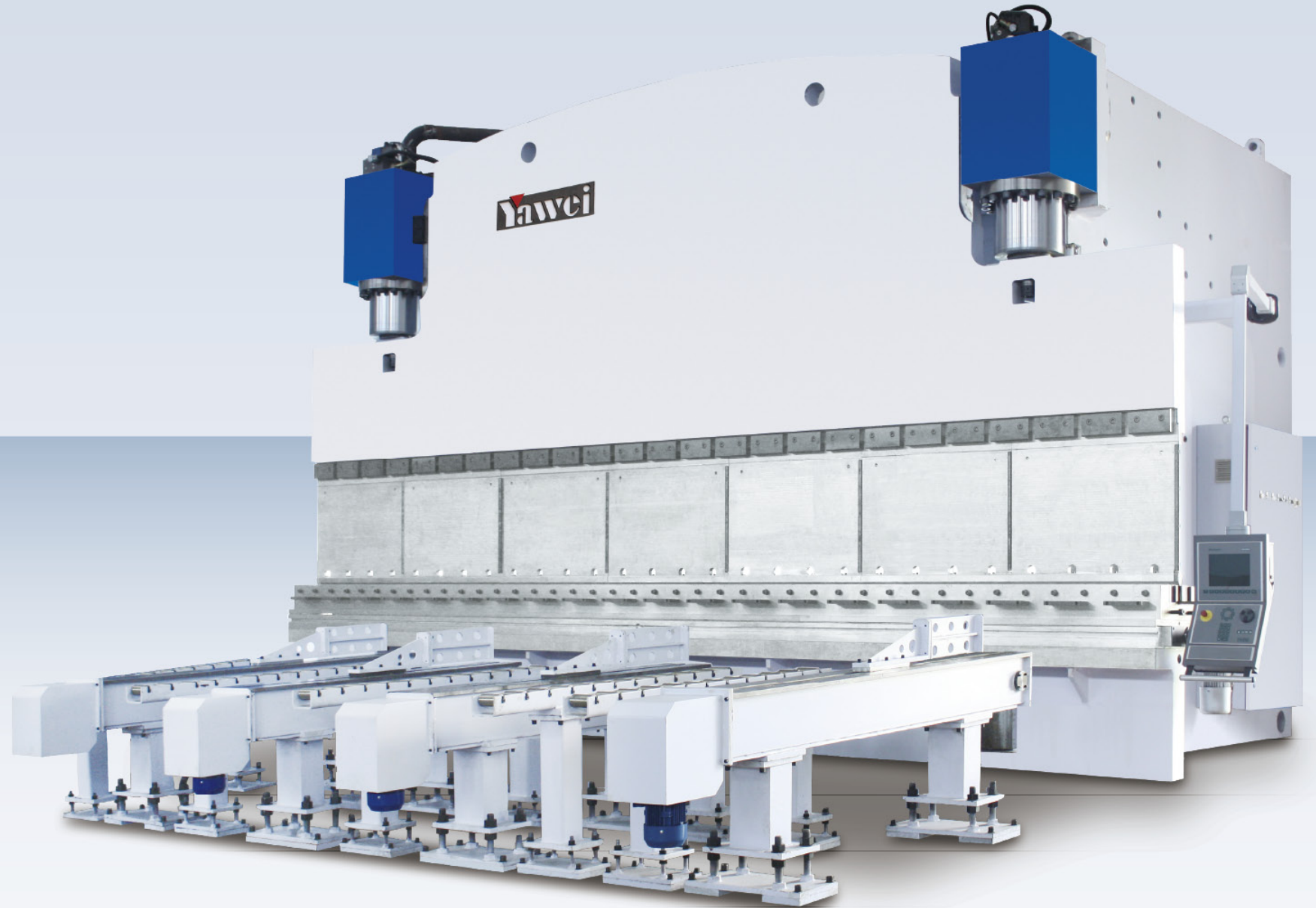

机械补偿剖视图
Sectional view of mechanical
crowning compensation

机械挠度补偿工作台，可以在工作台全长上获得精确的挠度补偿。加凸工作台由一组带斜面的加凸楔块组成，每个加凸楔块是根据滑块、工作台立板有限元分析的挠度曲线设计而成。数控系统根据工件折弯是负载力的大小（该力将导致滑块和工作台立板产生挠度变形），计算所需的补偿量，自动控制加凸楔块的相对移动量，从而有效地补偿了滑块和工作台立板产生的挠度变形，能得到理想的折弯工件。

The CNC Mechanical bed crowning system utilizes a beveled wedge style for compensation. The CNC system calculates the needed crowning based on the force during the bending process (to compensate for deflection during the bending process) and adjust the wedges accordingly. This effectively compensates for the deflection caused during the bending process ensure a quality part for the full length of the bend.

PBH(A)系列大型折弯机

PBH(A) Series Heavy Duty Pressbrake

标准配置

- 数控系统标配DA52S
- 液压控制系统采用德国全闭环电液伺服同步控制系统
- 后挡料前后运动X轴，挡指可沿导轨移动
- 直联型夹紧上模、机械斜楔夹紧欧式上模
- 多V宽工作台夹紧下模
- 前托架位置可沿工作台方向按步距调节

Standard Configuration

- Adopt Delem DA56S CNC Control from the Netherlands
- Hydraulic system is a full loop electro hydraulic servo control system from Germany
- X Axis Backgauge with movable fingers along swallowtail gauge
- Direct Link Type Clamping or European Style Mechanical Wedge Clamping for Upper Tools
- Multi-V with wide worktable for bottom die
- Front support can be adjusted along worktable by step

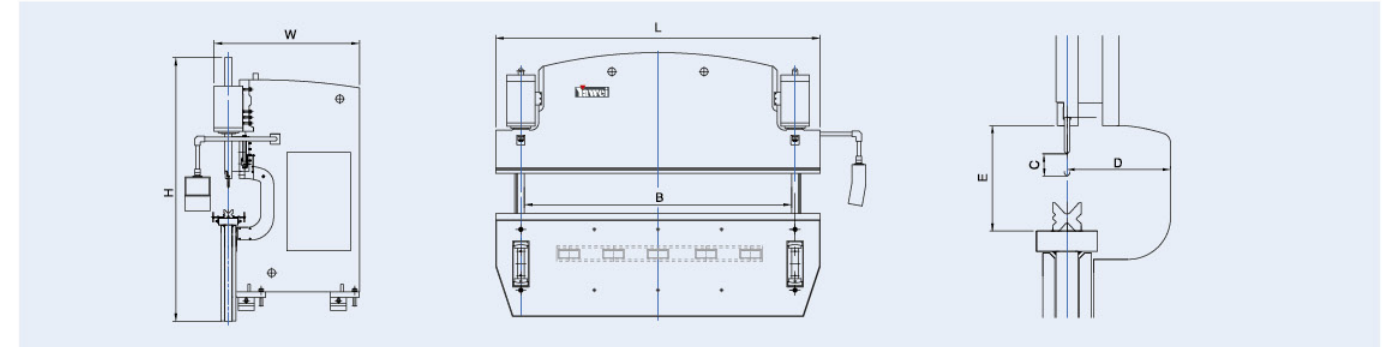

技术参数 Technical Specifications

型号 Model	公称力 Nominal pressure	工作台长度 A Length of worktable A	立柱间距B Distance between uprightsB	喉口D Throat depth D	滑块行程C Ram stroke C	最大开启高度 EMax. day light E	滑块速度 Ram speed			电机功率 Motor power	油箱容积 Tank volume	外形尺寸 Overall dimension L x W x H	机床总重量 Weight
	kM	mm	mm	mm	mm	mm	mm/s			kW	L	mm	kg
PBH-160/5100	1600	5100	4200	410	215	400	120	10	110	11	600	5400x1850x3350	21000
PBH-220/5100	2200	5100	4200	410	215	400	120	10	110	15	750	5400x1860x3380	24000
PBH-220/6200		800	6500x1850x3430								28000		
PBH-300/5100	3000	5100	4200	410	265	500	120	10	100	22	800	5400x2000x3360	29000
PBH-300/6200		900	6500x2000x3610								35000		
PBH(A)-400/4100	4000	4100	3200	510	315	520	110	9	100	30	1000	4400x2150x3480	27000/25000
PBH(A)-400/5100		1050	5400x2160x3880								35500/30000		
PBH(A)-400/6200		1200	6500x2160x3910								43000/33000		
PBH(A)-500/4100	5000	4100	3200	510	315	520	100	9	90	37	1050	4400x2190x3700	33000/30000
PBH(A)-500/5100		1200	5400x2290x4200								43000/33000		
PBH(A)-500/6200		1300	6500x2290x4500								53000/45000		
PBH(A)-500/8200		1300	8500x2290x5400								76000/64000		
PBH(A)-630/4100	6300	4100	3200	510	315	620	100	9	90	45	1200	4400x2430x4000	46000/41000
PBH(A)-630/5100		1200	5400x2430x4200								62000/55000		
PBH(A)-630/6200		1200	6500x2430x4500								68000/58000		
PBH(A)-630/8200		1500	8500x2430x4630								85000/69000		
PBH(A)-800/6200	8000	6200	5100	610	410	720	100	9	80	75	1500	6500x2990x5000	89000/77000
PBH(A)-800/8200		1800	8500x2990x5400								125000/115000		
PBH(A)-1000/6200	10000	6200	5100	610	410	720	100	9	80	90	1500	6500x2760x4800	102000/87000
PBH(A)-1000/8200		2000	8500x2760x5300								130000/112000		
PBH(A)-1200/6200	12000	6200	5100	610	410	720	90	8	70	90	1600	6500x2940x5000	110000/95000
PBH(A)-1200/8200		2100	8500x2940x5400								148000/130000		
PBH(A)-1200/12000		2500	12200x3700x7900					250000/210000					
PBH(A)-1600/8200	16000	8200	6500	610	410	720	70	7	60	2x55	3000	8500x3300x6700	220000/190000
PBH(A)-1600/12000		12000	9500	1000	500	1250	70	7	60	2x55	3000	12200x4700x9900	350000/290000
PBH(A)-2000/12000	20000	12000	9500	1250	600	1600	70	7	60	2x75	3600	12200x4700x9900	420000/355000
PBH(A)-2500/12000	25000	12000	9500	1500	600	1900	70	6	50	2x75	3600	12200x5300x9900	490000/430000
PBH(A)-3000/12000	30000	12000	9500	1500	600	1900	70	6	50	2x90	4200	12200x3740x8800	600000/520000

PBA钢管杆双机系列折弯机

PBA Series Tandem CNC Pressbrake for Steel Pipe Pole

标准配置 Standard Configuration

- 非对称结构设计, 适合钢杆塔“厚板不长, 长板不厚”的特点
 - 可调式下模, V型槽开口步距调节, 可适应不同板厚、折弯圆弧的需求
 - 可换式上模头, 有棱形和圆弧形选择, 满足各种钢杆的加工需求
 - 前后送料装置, 变频电机控制, 手动控制, 位置数显, 减轻人工强度, 提高送料效率
 - 侧出料装置, 模具区域嵌入式滚轮设计, 出料更轻松, 出料架对称式滚轮设计, 手轮调节距离, 操作更方便
- Asymmetrical structure design, suitable for the feature of steel pole "the thick plate is not long, the long plate is not thick"
 - Bottom die has V shaped groove opening and is step adjustable to meet requirements of different thickness and bending angles
 - Changable upper tool to primatic or circular shapes to meet many different requirements of different steel poles
 - Front and Back feeding devices, controlled by variable frequency motors with manual controls and digital displays for position. This reduces labor and increases efficiency
 - Side discharge device with rollers inlayed in the tool area to make the removal of the part easier and symmetrical rollers designed in the discharge frame. The distance is controlled by hand wheels and is very user friendly

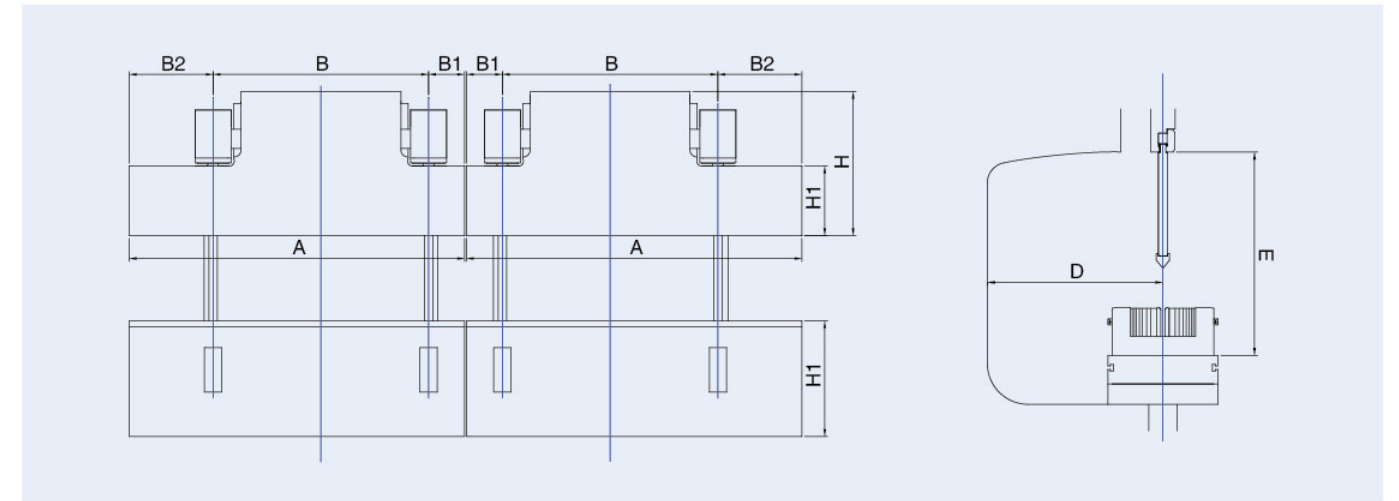

技术参数 Technical Specifications

型号 Model	油缸中心距 Center distance of oil cylinder	喉口深度 Throat depth	滑块行程 Ram stroke	最大开启高度 Max. day light	下模最大开口 Max. die opening	工作台宽度 Worktable width	滑块速度 Ram speed			电机功率 Motor power	不掉头折弯单缝管对边距 Across flat of bending single slit tube without turning around Octagon		不掉头折弯双缝管对边距 Across flat of bending double slit tube without turning around Octagon		调头折弯双缝管对边距 Across flat of bending double slit tube with turning around Octagon		折弯最大板厚 × 板宽 Max. bending thickness × width		机器总重 Weight
											8边形 8 Dodeca-gon	12边形 12 Do-decagon	8边形 8 Dodeca-gon	12边形 12 Do-decagon	8边形 8 Dodeca-gon	12边形 12 Dodeca-gon			
2-PBA- x / x	mm	mm	mm	mm	mm	mm	mm/s			kw	mm	mm	mm	mm	mm	mm	mm × dm	mm × dm	kg
500/6000	4500	1000	315	1100	280	500	100	9	90	2x37	500	480	900	850	1380	1540	19x100	17x120	135000
500/7000	5200																17x120	16x140	150000
630/6000	4500	1100	315	1200	280	500	100	9	90	2x45	560	550	1030	950	1550	1720	23x100	21x120	150000
630/7000	5200																21x120	19x140	162000
800/6000	4500	1100	410	1200	280	500	100	9	90	2x75	560	550	1030	950	1550	1720	26x100	24x120	184000
800/7000	5200																24x120	22x140	202000
800/8000	6000																22x140	20x160	223000
1000/7000	5200	1600	410	1250	320	600	100	9	90	2x90	815	805	1500	1380	2260	2240	28x120	26x140	253000
1000/8000	6000																26x140	24x160	279000
1200/7000	5200	1600	410	1250	320	600	90	8	80	2x90	815	805	1500	1380	2260	2240	30x120	28x140	288000
1200/8000	6000																28x140	26x160	317000
1600/7000	4500	1600	410	1600	320	600	70	7	70	4x55	815	805	1500	1380	2260	2510	38x120	35x140	347000
1600/8000	5200																35x140	32x160	372000
2000/8000	5200	1600	410	1600	320	600	70	6	70	4x55	815	805	1500	1380	2260	2510	38x140	36x160	465000

大型折弯机 通用部件

Options for Heavy Duty Pressbrake

可供选择的后挡料部件 Backgauge Options

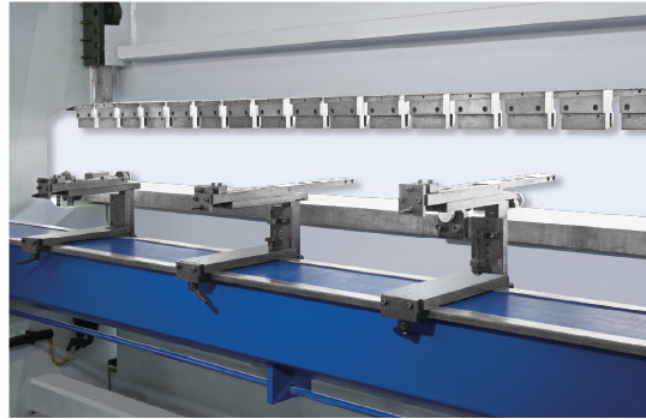

H型后挡料3C H-type Backgauge 3C

- 箱式挡料梁结构，刚性高，稳定性高
- 二级挡指结构，扩大档料范围
- 配置X轴，伺服驱动，数控系统自动控制，定位精度高
- 挡指沿导轨左右移动
- Box tube beam construction for extreme rigidity and stability
- Two step finger design to increase bending flange length
- X axis controlled by an AC servo motor and programmed through the CNC for excellent positioning accuracy
- Fingers move left and right along the swallowtail guide



重型后挡料3C Heavy Duty Backgauge 3C

- 壳体卧式安装结构，稳定性高
- 单壳体双导轨导向，精度高
- 配置X轴，伺服驱动，控制系统自动控制
- 挡指沿导轨左右移动，抗冲击能力强
- Solid horizontal beam construction for exceptional stability
- Single rail construction with dual guided linear ways for high precision
- X axis controlled by an AC servo motor and programmed through the CNC for excellent positioning accuracy
- Finger move left and right along linear ways



重型后挡料4C Heavy Duty Backgauge 4C

- 壳体卧式安装结构，稳定性高
- 单壳体双导轨导向，精度高
- 配置X轴和R轴，伺服驱动，控制系统自动控制
- 挡指沿导轨左右移动，抗冲击能力强
- Solid horizontal beam construction for exceptional stability
- Single rail construction with dual guided linear ways for high precision Z axis movement
- X and R axis controlled by an AC servo motors and programmed through the CNC for excellent positioning accuracy
- Finger move left and right along linear ways

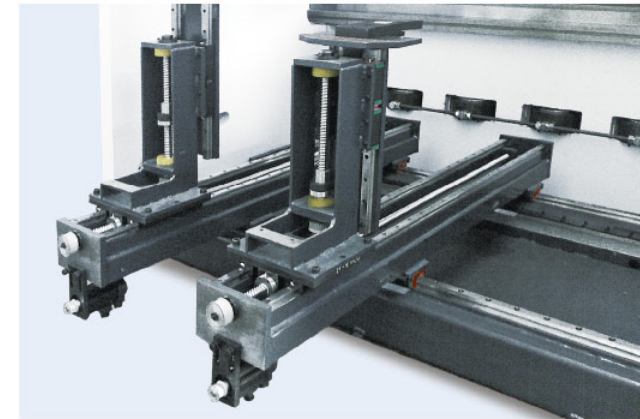

6轴后挡料 6-axis Backgauge

- 重载框架结构，刚性高，抗冲击能力强
- 配置X1、X2、R1、R2、Z1、Z2轴，伺服驱动，数控系统自动控制
- 适合不规则工件折弯挡料
- Heavy duty frame structure for excellent rigidity and high impact
- Axis include X1, X2, R1, R2, Z1 and Z2 all driven by servo motors and programmed through the CNC for excellent positioning accuracy
- Independent axis control allows you to bend irregular shaped or tapered parts easily



独立数控挡料 Independent CNC Gauge

- 前后挡料独立式结构
- 双直线导轨导向，精度高、稳定性高
- 配置X轴，大功率伺服驱动，数控系统自动控制
- 整个挡料沿直线导轨左右移动
- Independent front or rear gauge system
- Guided Dual-rail system for high precision and stability
- X axis is driven by high powered servo motor and programmed through the CNC for excellent positioning accuracy
- The gauge system moves left and right along linear guide

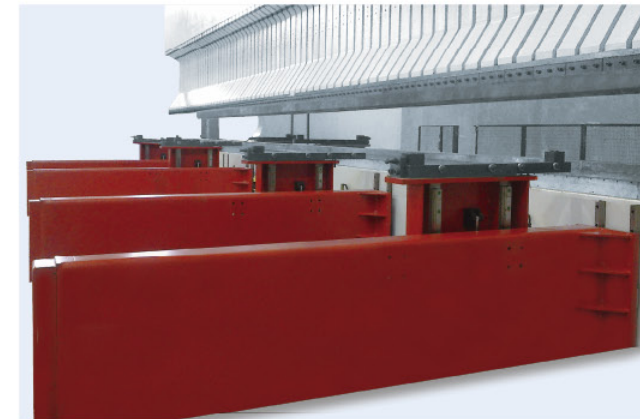

多功能数控挡料 Multi-functional CNC Gauge

- X轴：控制送料挡指前后移动
- R轴：控制送料挡指上下移动
- S轴：控制送料整体上下升降
- 挡料整体可降至地面以下，保证大工件折弯不干涉
- X axis: controls finger movement forward and backward
- R axis: controls finger movement up and down
- S axis: controls complete system up and down
- The complete gauge system can be lowered entirely below floor level eliminating interference during bending the process

大型折弯机 通用部件

Options for Heavy Duty Pressbrake

可供选择的下模结构 Optional Bottom Die Configurations

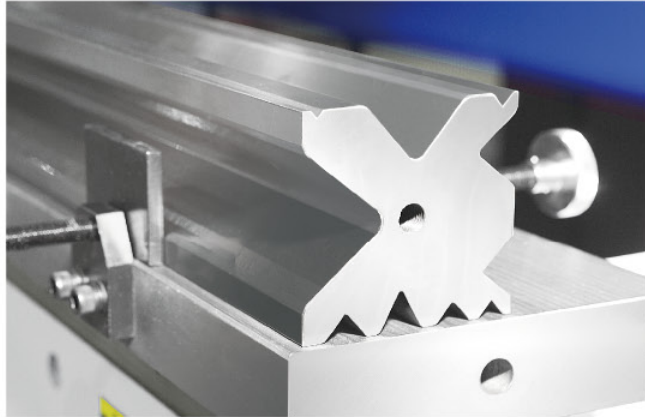

多V下模 Multi-V Bottom Die

- 标配多V下模，可选择不同开口和外形尺寸的设计，换模方便，可满足常规板材折弯加工，性价比较高
- Standard configuration is multi V bottom die, with multiple V openings and sizes to choose from easy change over via drilled and tapped holes in each end, is an economical way to meet all your bending needs



模口镶条式多V下模 Multi-V Bottom Die with Hardened Insert Bars

- 选配多V下模，可选择不同开口和外形尺寸的设计，模口镶高硬度条，耐磨性高，可满足高强度板材折弯加工，寿命长
- A Multi-V bottom die with hardened insert bars, with different V openings and sizes to choose from, The hardened inserts reduce wear increasing the life of your tools on high strength or abrasive steels

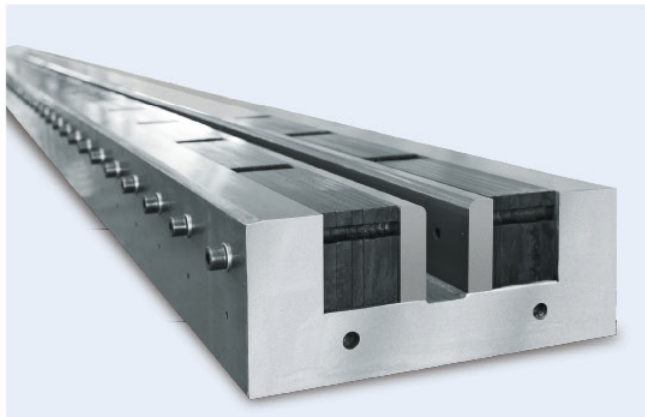

开口可调式下模 Bottom Die with Adjustable V

- 选配可调式下模，可选择不同开口尺寸的设计，模口采用高硬度材料设计，耐磨性高，可满足高强度板材折弯加工，寿命长
- An adjustable Bottom die is an option to accommodate a wide range of materials, This die is designed for use with high strength or abrasive steels to reduce wear and increase life of the die

其它辅机 Additional Options Material Handling

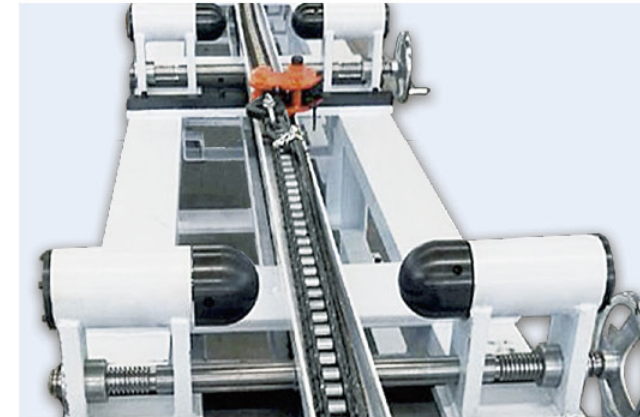

侧出料单元 Electric Drive Side Discharge

- 普通电机驱动、链条传动，安全系数大
- 对称式滚轮结构，手轮调节间距，以适应不同的管径
- 出料架长度可定制
- Motor and chain driven for easy material removal
- Symmetrical roller structure adjustable via hand wheels to accommodate a wide range of pipe diameters
- Customized lengths available

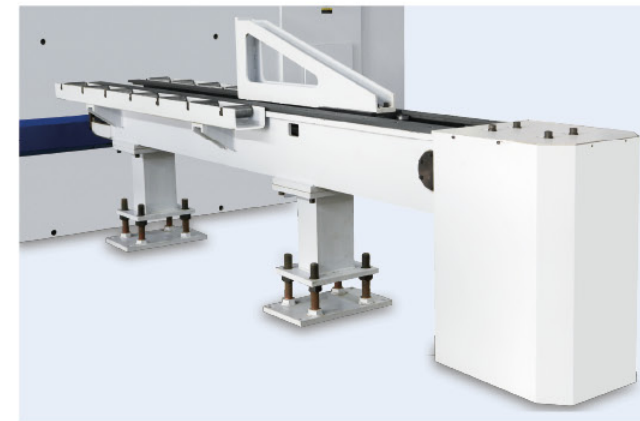

电动推料单元 Electric Drive Front Material Feed

- 普通电机驱动、链条传动，安全系数大
- 特殊的链条涨紧结构可以使传动精度更高
- 适用于制管行业
- Motor and chain driven for easy material handling
- High precision movement via a special chain tension structure
- Applicable for pipe bending

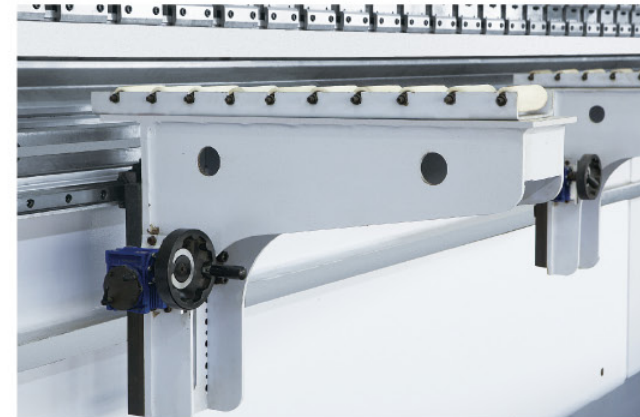

特殊前托架 Top Roller Front Sheet Supports

- 防划伤滚轮设计，保护板材
- 手轮升降，可沿直线导轨左右移动
- Roller design to prevent scratching or marking of plates
- Adjust height by hand wheel, moving left and right along linear guide

装备精良 质量保障

Well-equipped, Quality Assured



- 埋弧式拼焊
- 生产效率高
- 焊缝质量高
- 劳动条件好
- Submerged-Arc Welding
- High Work Efficiency
- High Quality Weld Joints
- Good working condition

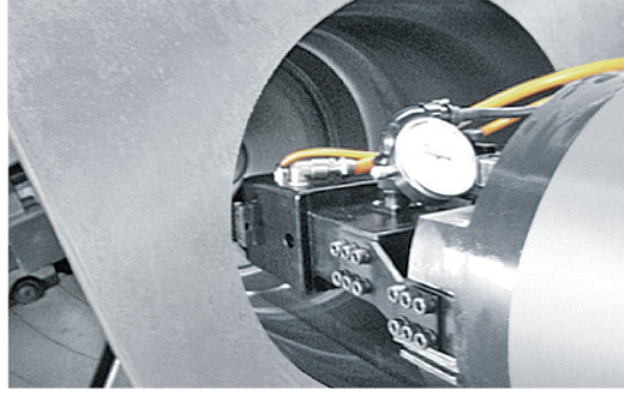

- 油缸专用加工设备，加工精度高
- 先进的加工工艺，是油缸精度的可靠保证
- High precision machining centers for the production of hydraulic cylinders
- Advanced processing technology, to ensure precision of oil cylinder



- 14米五面体加工中心
- 加工大型结构件，一次装夹加工成形，保证模具安装精度、运动轨迹精度，从而保证制件精度
- 14 meters Pentahedron Machining Center
- One set up insures precision machining for large structural parts



- 20米曲臂升降车
- 强大而先进的内部安装设施
- 20 meters lift truck
- Advanced onsite installation facilities

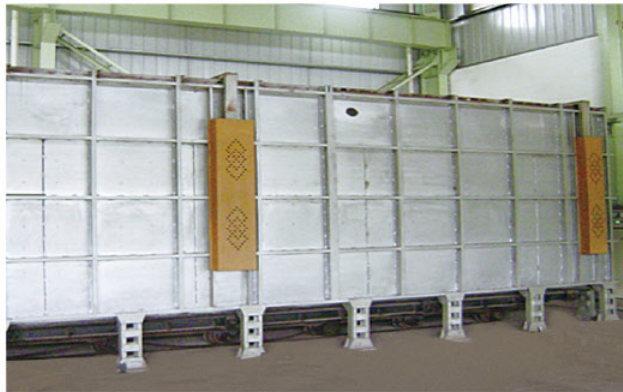

- 20米大型回火炉
- 消除焊接应力
- 改善机械性能
- 20 Meter Long Stress Relieving Furnace
- Relief of welded joints
- Improving mechanical properties



- 数控大车床
- 2500mm的旋转半径专门生产大型油缸
- Big CNC lathe
- 2500 mm Large Lathe Specialized for turning radius of large hydraulic cylinders



- 20米数控镗铣床
- 在专门的工装模拟工件安装状态下加工，保证工件安装后精度
- 20 meters CNC Boring and Milling Machining Center
- With Specialized Tooling parts can be machined in a single set up to ensure precision during the assembly process



- 150吨行车
- 大型的起吊设备保证了安装精度和可靠性
- 150 Ton Capacity Crane
- Large capacity Equipment allows precise and reliable installation during the assembly process

典型行业 客户案例

Customer Installations



山东2-2000/8000
Shangdong 2-2000/8000



常州3200/8000
Changzhou 3200/8000



合肥2500/13000
Hefei 2500/13000



郑州2000/12000
Zhengzhou 2000/12000



江阴2500/8100+2200/6100
Jiangyin 2500/8100+2200/6100

典型行业 客户案例

Customer Installations



加拿大2000/12300 Canada 2000/12300



美国3000/18000 USA 3000/18000



波兰2000/15200 Poland 2000/15200



德国2-2500/13000 Germany 2-2500/13000

量身定制 解决方案

Customized Solution Provider



定制模具
Customized Tools



典型工件折弯
Typical Bending Application

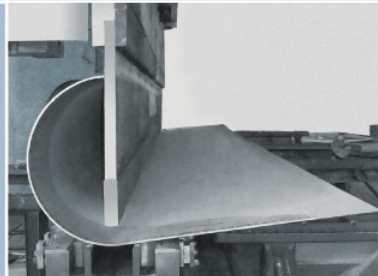

广泛的应用
Wide Range of Applications

为不同行业提供最优解决方案

Yawei provides the best sheet metal solutions for all industries

亚威股份是一个全球化的金属板料加工解决方案与服务支持的供应商。公司在全球范围内生产定制机床已有30多年的丰富经验，技术不断创新进步。我们提供高质量的解决方案和服务，使得全球多个国家的用户获得了超值的回报，在很多特殊的行业，YAWEI折弯机担负起特殊的重任，如汽车吊臂、钢管塔、油气管、钢结构桥梁、大型变压器、矿山机械等。

Yawei is a globalized solution provider for sheetmetal processing, service and support. Yawei has over 30 years of experience in the manufacturing and customization of machine tools on a global scale, with a continued progress of technologies and innovations. We offer high quality service and solutions that enable many of our customer to receive value-added returns. Yawei's Pressbrake are used for production in many industries from cranes, steel towers, oil and gas pipes, structural steel bridges, large scale transformers, and mining equipment.

全面的产品服务支持

Overall product service and support

所有售出机床都包括全面的质量保证和完善的培训，此外我们还为用户提供广泛的服务，包括定期的走访调查、及时的售后服务、远程诊断、应用支持等。全面的培训课程可以满足每一个用户的不同需求。

All machines go through a comprehensive inspection and quality assurance process prior to shipping, We also provide a wide range of services after the sale, including regular customer visit, short lead time service, remote diagnostics and application support, Our comprehensive training courses will satisfy every customers needs and requirements.

江苏亚威机床股份有限公司

JIANGSU YAWEI MACHINETOOL CO., LTD.

中国

江苏扬州市江都区黄海南路仙城工业园

邮编: 225200

销售电话: 0514-86880518 86880528 86519118

售后服务: 0514-86880538 86519128 86519158

配件销售: 0514-86519148

传真: 0514-86882218 86519188

网址: www.yawei.cc

电邮: sales1@yawei.cc

INTERNATIONAL

XIANCHENG INDUSTRIAL ZONE, HUANGHAI SOUTH ROAD

JIANGDU DIST. 225200 YANGZHOU, JIANGSU, CHINA

Sales hot line: +86-514-86880517 +86-514-86880518

Service phone: +86-514-86880517 +86-514-86880538

Part sales phone: +86-514-86519148

FAX: +86-514-86880521 +86-514-86882218

HTTP: www.yawei.cc

Email: sales2@yawei.cc



Yawei 亚威

以上两个标志皆为江苏亚威机床股份有限公司的商标

The above two marks both are commercial brand of Jiangsu Yawei Machine Tool Co., Ltd.

产品不断改进, 样本如有变动恕不另行通知

The contents are subject to change without prior notice



亚威公众微信
YAWEI WeChat